

# **Mills Historic Information Summary - 5**

## **New Hill**

### **Nitroglycerine Factory 1941      Firing Points 195?**



**New Hill Nitroglycerine Factory WAI 245-02**

Following the 1940 Edmonsey Mixing House explosion, the subsequent Enquiry recommended that, as well as rebuilding the Edmonsey facilities, a back up Nitroglycerine Factory should also be built and this was completed (by Wimpey) in 1941, the development termed New Hill.

The Factory was never actually used for production and in the 1950's the site was adapted to create Firing Points.

The New Hill, with its history of adaptation of original explosives chemical engineering buildings to a totally different explosives role, is a unique site unknown to the outside world and this Historical Summary has been written as a historical record and for possible quick reference in the event of development of the site.

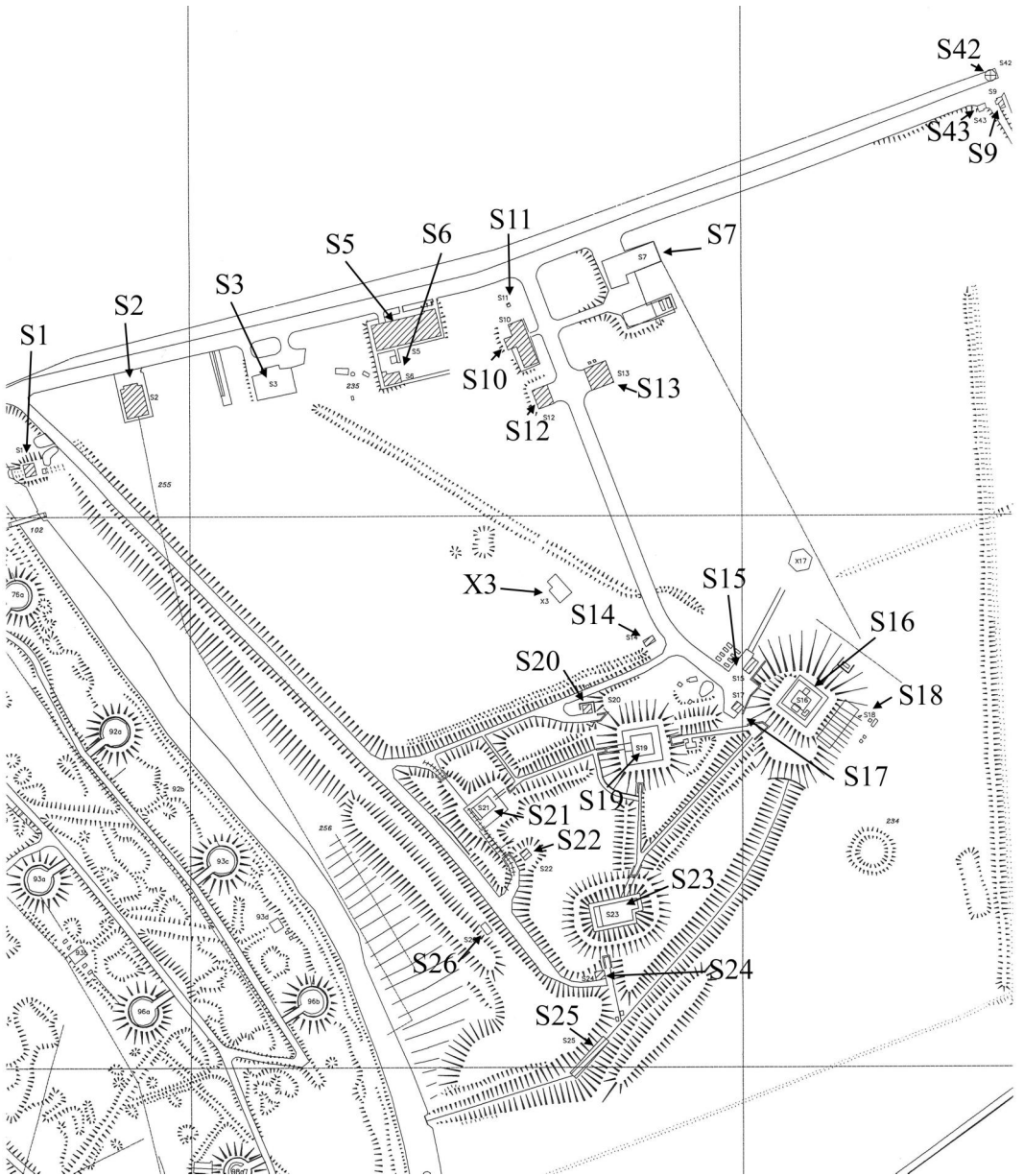

**New Hill WAMP 163-14**

## New Hill Nitroglycerine factory

Based on last available data – RCHME 1993

Bldg No.	Year	Function	Bldg No.	Year	Function
S1	1941	Pump Ho.	S15	1941	Plenum Heater House
			"	195?	Firing Point 1 Control Room.
S2	1941	Electricity sub sta.	S16	1941	Nitrating House
"	195?	Transformer Ho.	"	195?	Firing Point 1
S3	1941	Store	S17	1941	Expense Mag.
"			"	195?	Firing Point 1 Control Room.
S5	1941	Charge Machinery	S18	1941	Part of S16
"	195?	Processing Room	"	195?	Compressor Room (part S16)
S6	1941	Lavatories	S19	1941	Washing House
			"	195?	Firing Point 2
S7	1941	Nitromethane Store	S20	1941	Plenum Heater House
			"	195?	Firing Point 2 Control Room
S9	1941	Police Gate house	S21	1941	Mixing House
			"	195?	Part converted to Firing Point
S10	1941	Dark Room	S22	1941	Plenum Heater House
			"	195?	Firing Point 2 Control Room.
S11	1941	Shed	S23	1941	Wash Water Settling House
S12	1941	Fuel Store	S24	1941	Plenum heater House
			"	195?	Control Room ?

Bldg No.	Year	Function	Bldg No.	Year	Function
S13	1941	Store	S25	1941	Flume Unit House
S14	1941	Solex fuel Store	"	195?	Charge assembly
			S27	1941	Magazine (demolished)
			S42	1941	Pillbox
			S43	1941	Police Gate House
			X3	1941	Concrete Filled Sandbag Bunker

## New Hill Nitroglycerine Factory

Gravity based

Processing material - - Mixed acids, (also compressed air and steam heating) By pipeline From N. Site Acid factory To

**Nitrator** S 16 ( later FP 1 ) Nitroglycerine To

**Washing House** S 19 (later FP 2 )

Contaminated waters from Nitrator and Washing House.. To

**Wash Water Settling House** S 23

Washed Nitroglycerine to **Mixing House** S 21 To

Railway to North Site

Wash water from Wash Water Settling House To

**Flume House** S 25 To

Filtered Water from Flume House To Cornmill Stream

## New Hill Firing Points

Due it is believed to difficulties with the acid pipeline, the Nitroglycerine Factory never went into production and in the 1950's within the earth mounds of certain Factory buildings Firing Points were constructed, with other buildings utilised as control rooms.

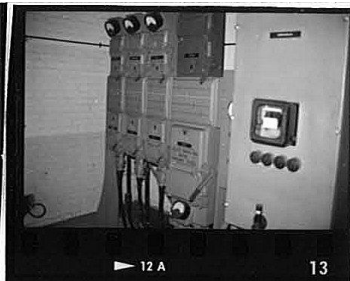

## S2 Electricity Sub Station



**S9 Police Gate House**



**S43 Police Gate House**



**S15 1941 Plenum Heater House 195? FP 1 Control Room**



**S16 1941 Nitrating House      195? Firing Point 1**



**S17 1941 Expense Magazine 195? FP 1 Control Room**





**S19 1941 Washing House 195? Firing Point 2**



**S20 1941 Plenum Heater House 195? FP2 Control Room**

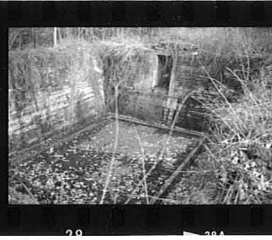

**S21 1941 Mixing House 195? Part Converted to Firing Point**



**S22 1941 Plenum Heater House  
195? FP2 Control room**



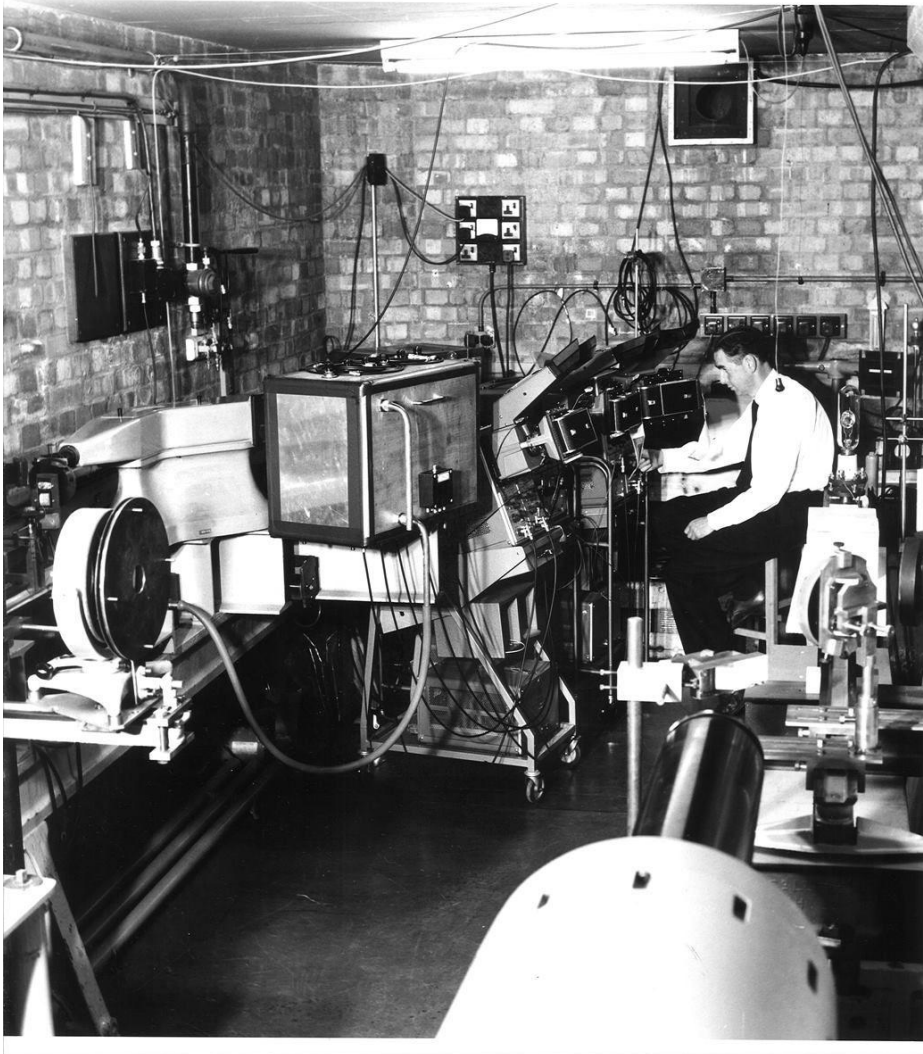

**WAI 409\_01 Firing Point No. 2 Control Room  
Tony Burton at work**

**Les Tucker (Royal Gunpowder Mills Friends Association)**

**View Mills Archive Online -**  
[https://www.wargm.org/archive\\_viewer](https://www.wargm.org/archive_viewer)